



Date  
Country

# BUILDINGS TECHNOLOGIES ASEAN

Product portfolio

**Honeywell**  
THE POWER OF **CONNECTED**



Honeywell is building a smarter, safer, and more sustainable world.

**That's the Power of Connected.  
That's the Power of Honeywell.**

# Honeywell at a Glance

NYSE **HON**  
FORTUNE  
**100**



headquarters  
**Morris Plains**  
New Jersey, USA

More than  
**131,000**  
employees



**1300** sites  
in **79** countries



2017 sales  
**\$40.5B**

## Aerospace

**\$14.8B**  
Sales

Mechanical, Cockpit,  
and Software Offerings  
From Nose to Tail

Apps, Services,  
Maintenance,  
Subscriptions

End-to-End Connectivity  
Solutions From  
Hardware to Airtime

Turbochargers for Fuel  
Efficiency

## Performance Materials and Technologies

**\$10.3B**  
Sales

Refining and Petrochemical Catalysts

Gas Processing Modular Offerings

Solstice® LGWP Materials

SmartLine Transmitters

Asset Optimization Software



## Safety and Productivity Solutions

**\$5.6B**  
Sales

Wireless, Voice, Mobility, Data Analytic Solutions for Workers

Warehouse Automation

Worker Safety

## Building Technologies

**\$9.8B**  
Sales

Security

Fire Protection

Home Comfort

Energy Efficiency

Open Software Connecting  
IoT in Buildings

# Buildings...customers needs are changing

80-90% time in buildings

Budget pressure & ROI scrutiny increasing

Productivity impact  
Increase:  
ventilation, lighting, temperature

Buildings consume  
>40% global energy consumption

Investors demanding green buildings for energy savings, lower operating cost

Introduction of international/ regional building standards

>80% building total life cycle cost occurs post construction

Heightened security physical & cyber

Customer expectations transcended into building ecosystems

# What are customer needs?



# Continuous Evolution Of Technology, Accelerating In Pace

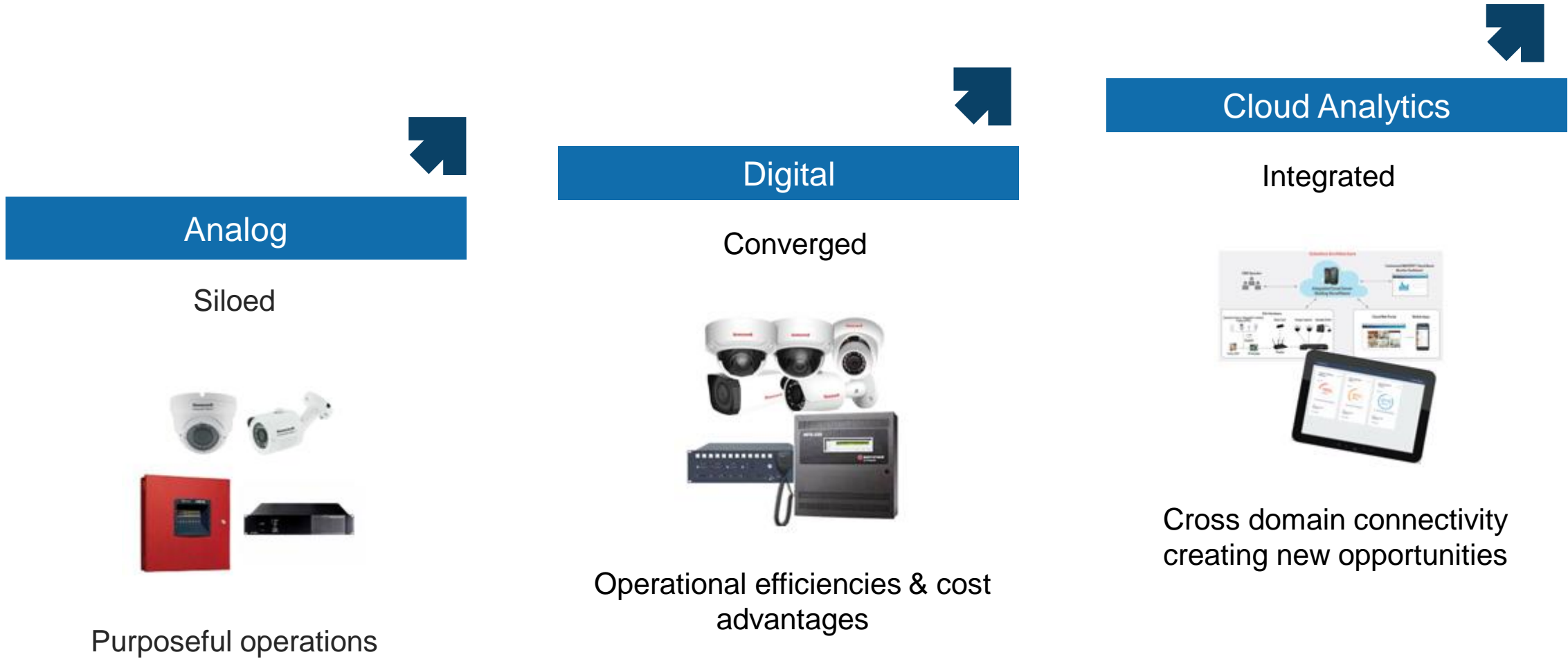

Honeywell Confidential - © 2018 by Honeywell International Inc. All rights reserved.

# Vision

FROM  
Industrial Automation



TO  
Software Industrial

- Connected Services
- Smart Buildings
- Smart Cities

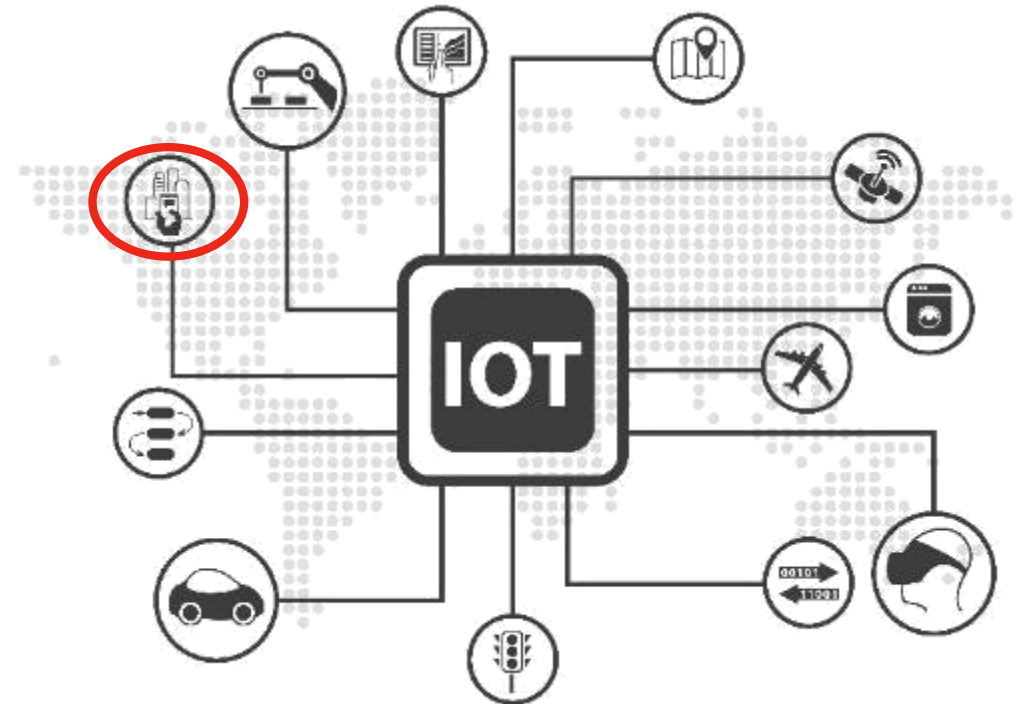



# Honeywell solutions deployed across various industries

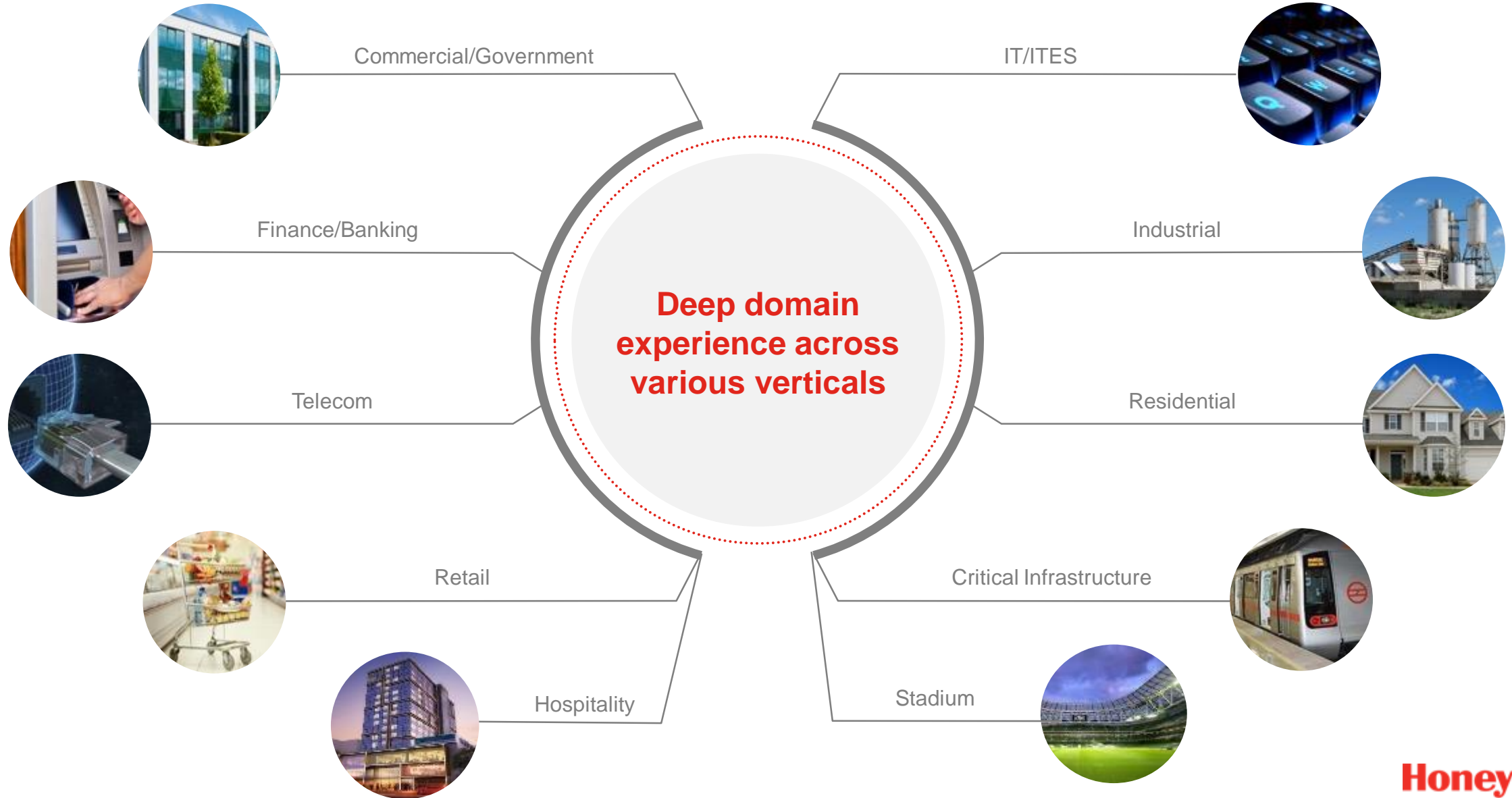

# Honeywell Building Technologies ASEAN



- **Ten** countries across ASEAN
- **700+** employees
- ASEAN headquarters in K.L.
- In-region Distribution Centre and Call Centre for better customer support



A broader and efficient portfolio of best-in-class products and end-to-end connected solutions



Dedicated Sales Teams aligned to segments i.e. Small Medium Businesses/ Enterprise/ Industrial/ Electrical Products/ Connected Living to provide the right value proposition



Strong presence and deep customer focus across all markets and geographies with dedicated Sales, Marketing, Technical expertise and distribution channels



Strong NPI funnel with ongoing investments in technology and R&D

# Buildings – Expectations Have Evolved

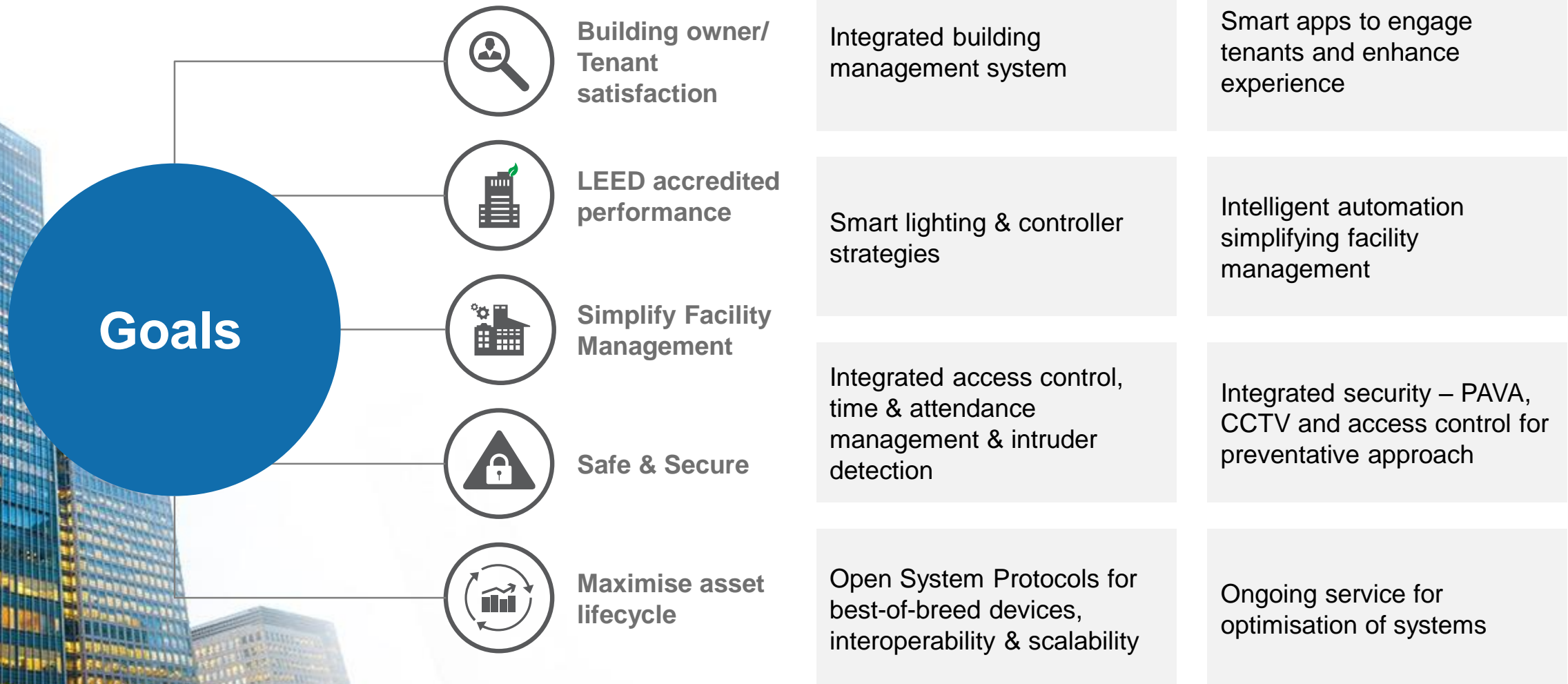

Honeywell Confidential - © 2018 by Honeywell International Inc. All rights reserved.

**We Work With 1500 Commercial Buildings, Our Experience Is To Your Advantage**

# Making your buildings work for you

## Connected Building

BUILDING  
MANAGEMENT  
SYSTEMS

CCTV

ACCESS CONTROL  
AND INTRUSION

VIDEO  
MANAGEMENT  
SYSTEMS

COMMUNICATION  
AND NOTIFICATION

FIRE DETECTION

WIRING DEVICES

CABLE  
MANAGEMENT  
SYSTEM

VALVES -  
MANUAL, CONTROL,  
WATER CONTROL,  
DIGITAL MANAGEMENT FLOW

AIR AND WATER  
PURIFIER

# Security

Whether you are a small business or the largest commercial enterprise, Honeywell has the right security solution for you

# There's a Perfect Solution for you

- Integrated video security for any size business or enterprise
- Superior video resolution and equipment performance
- Built-in security features
- Operational savings and increased productivity

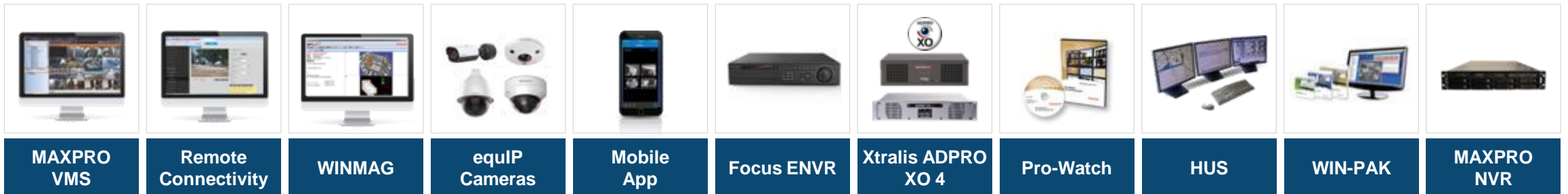

# Honeywell CCTV

## Supported Features



### High Resolution Cameras

Better picture quality to capture details of scene



### EDGE Analytics

With reduced false alarms, improves the efficiency of system



### Cybersecurity

Improved cyber protection measures for peace of mind



### Special Application Cameras

Certified models for meeting regulatory compliance



### HUE based Design

Improved User Experience

# Security - Benefits/ Solutions:

## Minimized inventory shrinkage

- High-resolution 4K & multi-imager cameras for superior image quality and seamless recording, even in low-light conditions

## Reduced operation costs while protecting customers, staff, and property

- Integrated with Honeywell Active alert, customer to enjoy the advantage of reduced false alarms. Provide reliable inputs on People count, person entering restricted area etc
- Easy-to-use click & drag PTZ control
- N+1 Redundancy to ensure no loss of data
- HUS + Access Control + HUS-SDK as an integrated security system with 24/7 video surveillance and integration with third party systems

## Reduced hardware investment and maintenance costs

- H.265 codec for reduced video storage space and network bandwidth needs
- Re-use existing brackets of equip camera

## Improved overall surveillance with efficiency

- High resolution models for better coverage
- Advanced video analytics on edge for reduced false alarms

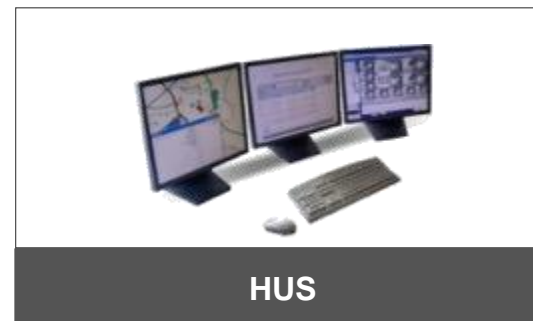
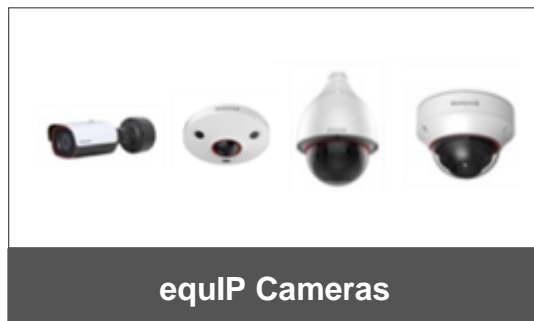



# Honeywell CCTV System

IP – 2 MP, 4 MP, 4K resolution models.  
Fisheye models for 360degree view



**4/8/16/32/64 Channel NVR**

**AHD**  
**HD**

**AHD – 1080P, HD over Coax**



#### Simple Installation

HD analog is as simple to install as standard analog CCTV cameras, DVRs and video surveillance systems - with no networking or licensing requirements.



#### Zero Latency

HD analog delivers high-definition video in real-time, with smooth motion and without the transmission delays commonly experienced with IP solutions.



#### Low Cabling Requirements

Transmit HD video fast – and with high signal quality – over standard coaxial cable (RG59), twisted pair (Cat5/6), or most standard shielded CCTV cabling.



#### Longer Transmission

Transmit HD video up to 1000' over standard coaxial cable (RG59) – up to 2X the distance of Analog solutions, and 3X the distance of IP systems.



#### Transition Friendly

HD Analog solutions are compatible with existing analog CCTV cameras and can leverage existing coaxial cabling, dramatically reducing the time and cost associated with a transition.



#### Cost-Effective

HD Analog technology is competitively priced vs. less-powerful traditional Analog gear, and a fraction of the cost of a comparable megapixel IP solution.

- OPEN STANDARD - compatible with all AHD OEMs
- Tribid DVR support standard analog + AHD + IP Camera
- CCTV support AHD + CVBS + CVI + TVI
- Longest transmission using coaxial cable
- Low Cost system

# WINPAK Portfolio

Honeywell's WIN-PAK® is an on premise connected security suite for mid commercial customers. It helps you meet your access control requirements for your business, and reduces your total cost of ownership by increasing operator productivity while providing flexibility and scalability.



## WIN-PAK 4.5 XE/SE/PE

Software solution for a cost-effective way to integrate and manage access control, video surveillance, intrusion detection through a single interface

## Intelligent Controller

PRO3000 and PRO3200 are advanced access control panels for medium to large applications.



# WIN-PAK 4.5

## Supported Features

One Platform Integration	Scalable System	Browser Management	Capability to integrate with 3 <sup>rd</sup> party system
<ul style="list-style-type: none"><li>• Eliminates disparate systems and interfaces</li><li>• Integrated access, video, intrusion, and fire systems through one interface</li><li>• Coordinate intrusion, access, or fire* events with video actions to maximize awareness</li></ul>	<ul style="list-style-type: none"><li>• Scales as your business grows</li><li>• Unrestricted number of cardholders and system users</li><li>• Unrestricted number of sites and access points</li></ul>	<ul style="list-style-type: none"><li>• Minimizes onboarding and training costs</li><li>• Intuitive web interface for access management, with embedded Help tool</li></ul>	<ul style="list-style-type: none"><li>• API is automatically installed with the web browser allowing technical support to validate the API is installed and ready for 3rd party integrations without any extra charge</li></ul>



# WINPAK for Hospitals/Clinics



## Improve (Wider) Employee Productivity via integrations

- Seamless integration with third-party solutions such as biometric readers, mobile credentials and in-house systems to drive productivity gains
- Mobile credential management reduces operator workload by up to 40%.
- Mobile system access improves operator efficiency, manage from anywhere
- Scheduled reports can be emailed ready when you need them.



## Reduce cost of facilities operation and management

- Buy what you need - modular platform allows you to grow
- Add additional doors, video and intrusion support as your business needs expand without replacing existing panels
- Access data can be used to monitor area/room usage to more efficiently manage space utilization
- Web client enhances scalability and reduces deployment and upgrade costs saving hours per year per workstation



## More Efficient/Effective Safety & Security

- Electronic Key management
- Tracking and Audit reports help meet compliances
- Manual / Emergency override control
- Door status viewer – See propped or unsecured doors.
- Doors locking schedules ensures doors are locked when they should be.

# ProWatch Portfolio

Honeywell's Pro-Watch® is a connected building platform for enterprise and critical infrastructure customers. It helps you meet the most stringent compliance requirements for your industry, and it reduces your total cost of ownership by increasing operator productivity with superior flexibility and scalability.

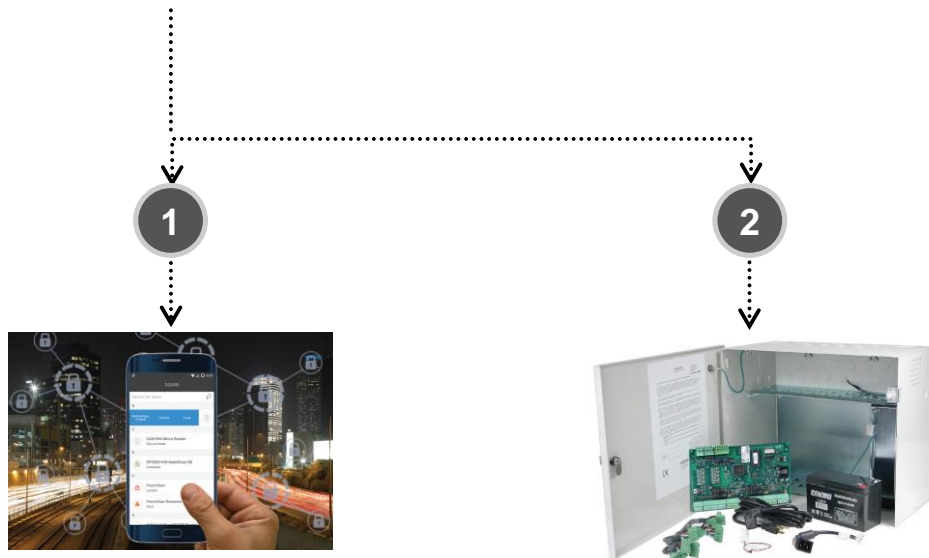

## ProWatch 4.3.5 PE/CE/EE

Provides a solid and proven platform for an intelligent business management solution with integration capability with HON access control, video, fire, and 3rd party systems.

## PW-Series Modular Control System

An advanced access control hardware architecture capable of providing solutions for large enterprise applications.



# ProWatch 4.3.5

## Supported Features

Web Based Clients – Badging & Reporting	Mobile Application	OSDP Support	Vendor Portal	Certification Management	Identity Management Portal	Compliance Report
<ul style="list-style-type: none"> <li>• Eases deployment</li> <li>• Reduces liability costs by providing the info required to ensure and monitor regulatory compliance</li> <li>• Reduces manpower costs, efficiently provides forensic data with minimal operator effort</li> </ul>	<ul style="list-style-type: none"> <li>• Easily access information and controls remotely, improving operator productivity</li> </ul>	<ul style="list-style-type: none"> <li>• Encrypted controller-to-reader communications enhances security</li> <li>• Custom messaging on supported display readers improves operational efficiency</li> <li>• Future functionality expansion to reduce total cost of ownership over the life of the system</li> </ul>	<ul style="list-style-type: none"> <li>• Vendors can proactively manage employees badging applications for TSA clearance</li> <li>• Real time view of badge status</li> <li>• Reporting and tracking reduces fees for companies by eliminating waste with badges expiring before being picked up or paying to extend viable applicants clearance deadlines</li> </ul>	<ul style="list-style-type: none"> <li>• Controls access to sensitive areas and ensures regulatory compliance</li> <li>• Improves productivity by automating access management to sensitive areas</li> </ul>	<ul style="list-style-type: none"> <li>• Improve productivity with web based workflows of access requests to area owners</li> <li>• Automated processing of access request eliminates entry errors to ensure compliance</li> </ul>	<ul style="list-style-type: none"> <li>• Reduces liability costs by providing info required to monitor regulatory compliance</li> <li>• Reduces manpower costs by efficiently providing forensic data with minimal operator effort</li> </ul>

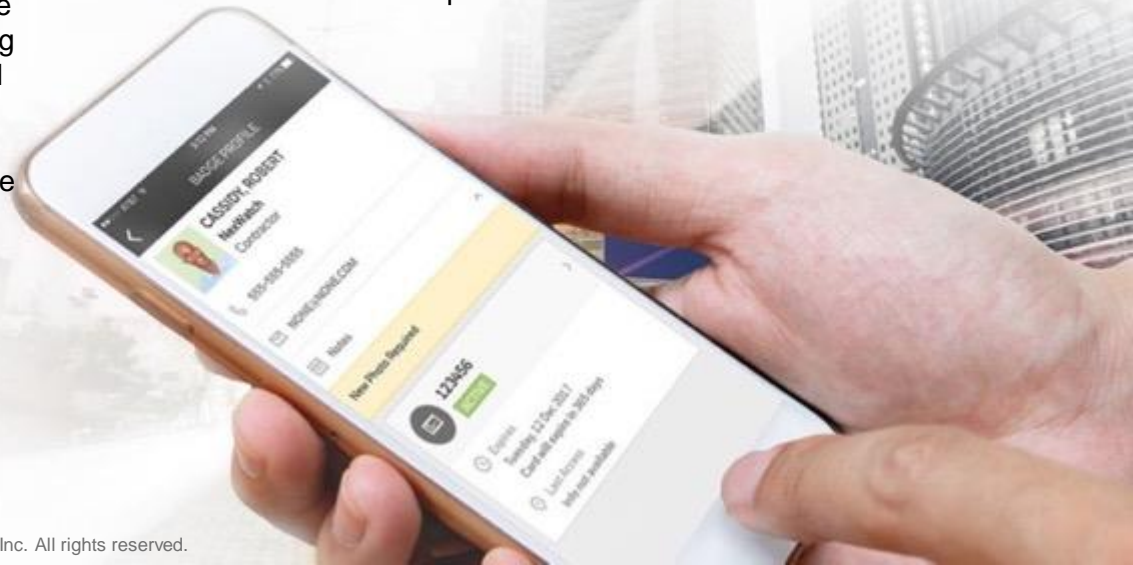

# ProWatch for Banking/ Finance



## Reduce cost of regulatory compliance

- Certification management to ensure compliance
- Extensive reporting to monitor compliance
- OSDP support delivers end-to-end encrypted security
- Complies with Sarbanes-Oxley



## Reduce cost of facilities operation and management

- Web clients reduce deployment costs by removing the need to update individual workstations
- Support of CASI and iSTAR replacement controllers provides a cost effective means of consolidating existing infrastructure



## Ensure safety & security more efficiently and effectively

- Pro-Watch mobile application improves operator efficiency
- Improvements in Web client reduce badging and reporting effort
- Direct support for issuing mobile credentials avoids double entry into separate systems
- Direct enrollment of Morpho Wave biometrics decreases operator workload
- ID Management portal reduces manpower required to manage access changes

# ProWatch for Industrial



## Reduce cost of regulatory compliance

- Certification management to ensure compliance
- Extensive reporting to monitor compliance
- OSDP support delivers end-to-end encrypted security
- Complies with NERC CIP



## Avoid any interruptions in business

- Web clients reduce deployment costs by removing the need to update individual workstations
- Support of CASI and iSTAR replacement controllers provides a cost effective means of consolidating existing infrastructure



## Minimize operational and management costs while protecting staff and property

- Pro-Watch mobile application improves operator efficiency
- Improvements in Web client reduce badging and reporting effort
- Direct support for issuing mobile credentials avoids double entry into separate systems
- ID Management portal reduces manpower required to manage access changes





# VISTA Intrusion Portfolio

Honeywell VISTA intrusion solutions provide you with all of the power and versatility you need to satisfy virtually any commercial installation requirement – all from a single platform. It provides excellent protection and advanced communications to help ensure that alarm signals get through to central.

It's the best way to stay protected and connected.



## Alarm Panel

The platform includes models listed for commercial fire, burglary and combination fire/burglary. The panels support up to 8 partitions and 250 zones using multiple technologies.



## Keypad

Easy to use, reduce training time and put security at your employees' fingertips.



## Sensor

Protecting your assets with variants of sensors from motion sensor, fire/smoke detector, and glass break detector



## Magnetic Contact



## Hold Up Devices

# VISTA Intrusion

## Supported Features

### Single-Button Operation

- Arm the system, turn lights on and off, send a page, or
- Display time with the press of one button at the keypad.

### Scalable System

- VISTA is a powerful, scalable security system that is ideal for businesses of any scope or size, can be tailored to meet your exact requirements and grow with the changing needs of your company.
- You can have intrusion, fire, access control, remote monitoring and more on one flexible, upgradable system.

### Event Log

- Review up to 100 system events identified with a time/
- date stamp, right at the keypad.

### False Alarm Reduction

- Incorporates the latest false alarm reduction features, including Exit Delay Restart, Auto Stay, Cross Zoning and Cancel Verification.



# Fire Safety

We offer a variety of fire protection solutions by market-leading brands. From small buildings to complex applications

# Audible/ Visual Devices

## Audible Devices

- Sirens: Extremely loud devices generally limited in use to outdoor or heavy industrial areas.
- Speakers: Audible devices used in conjunction with voice evacuation messages.
- Horns: Loud and distinctive output. Often used in high noise environments.
- Sounders: Electronic or mechanical audible devices, which may have various outputs selected for their operation.
- Chimes: Soft-toned appliances used where loud noises could be disruptive to other operations. Generally used where qualified personnel are continuously in attendance.
- Bells: Only used if they are only for fire, or have a distinctive sound from other bell signaling devices. Often used as an external gong for Waterflow operation.



## Visual Devices

- Visual signaling devices are used in high noise environments, areas of occupancy by hearing impaired individuals, or other areas where additional signaling is desired.
- The device design and the signaling characteristics will attract people to the signal for proper notification.
- Light Pulse Characteristics
- Flash rate not less than 1 flash every 3 seconds (1/3 Hz), not more than 3 flashes per second (3 Hz).
- Maximum pulse duration cycle 0.2 seconds, with a duty cycle of 40%.
- Light source shall be clear or nominal white, and shall not exceed 1000 candela (cd).
- Description



# Honeywell Morley-IAS Product Range

## PANEL



**714/001/115**  
DXc1 One Loop  
Fire Alarm  
Control Panel



**714/001/225**  
DXc2 Two Loop  
Fire Alarm  
Control Panel

**714/001/245**  
DXc4 Four Loop  
Fire Alarm  
Control Panel

## REPEATER

### 709-601-001

Active Repeater.  
Silence, Mute, Reset,  
Accept, Evacuate and  
Test Controls.



### 709-701-001

Passive  
Repeater.



## MANUAL CALL POINT



**MI/MCP/FLEX** Red Add Call  
Point, Flush Mounting, Flexi  
Element

**HM/MCP/GLASS** Red Add Call  
Point, Flush Mounting, Glass  
**W5A-RP05SG-K013-01** WCP  
Red Addressable EN54  
Markings, Glass Element

**PS230** Pack of ten resettable  
elements.

**MUS041W** Surface Mounting  
Box, Red

## DETECTOR



**HM/PSE/S2** Smoke detector  
**HM/PTSE** Photo Thermal  
detector  
**HM/RHSE** ROR heat detector  
**HM/FHSE** Fixed heat detector  
**MI-HTSE-S2-IV 780C**  
Thermal Sensor  
**MI-PTIR-S2-IV**  
Smoke/Thermal/IR Sensor  
**HM/PSE/S2/I** Smoke detector  
with Isolator  
**HM/PTSE/I** Photo Thermal  
detector with Isolator  
**HM/RHSE/I** ROR heat  
detector with Isolator  
**HM/FHSE/I** Fixed heat  
detector with Isolator  
**MI-HTSE-S2I-IV 780C**  
Thermal Sensor with Isolator  
**MI-PTIR-S2I-I**  
Smoke/Thermal/IR Sensor  
with Isolator  
**MI/B501AP/IV** Sensor  
Mounting base.

## MODULES



**MI-DISO** Loop isolation  
module  
**MI-DMMI** Single Input  
Monitor Module  
**MI-DMM2I** Dual Input  
Monitor Module  
**MI-DCMO** Output control  
module  
**MI-D2ICMO** Dual input and  
single control output  
combination module.  
**MI-D240CMO** Output  
Control Module, 240Vac  
relay contact rating complete  
with surface enclosure.  
**MI-DCZRM** Conventional  
Zone Interface Module

## MODULES



**MI-MM3E-S2** "Micro"  
monitor module with  
status LED output



**M200E-SMB** Surface  
Mounting Box



**M200E-DIN** DIN rail  
mounting clip

### 795-122

DXc RS232 Card allows  
the connection of a serial  
device to the panel such  
as TG Software

## AUDIO VISUAL



**WSO-PR-N05** Intelligent Wall  
Mounted Sounder, Red with Pure  
White skirt

**WSO-PR-I05** Intelligent Wall  
Mounted Sounder, Red  
with Isolation

**WSS-PR-N05** Intelligent Wall  
Mounted Sounder Strobe, Pure  
White skirt, Red lens

**WSS-PR-I05** Intelligent Wall  
Mounted Sounder Strobe, Red  
with Isolation

**WST-PR-N05** Intelligent Wall  
Mounted Strobe with red lens.

**WST-PR-I05** Intelligent Wall  
Mounted Strobe with red lens and  
built in isolator.

**BSO-DD-N05** Intelligent  
Integrated Detector Base  
Sounder,  
Detector White

**BSO-DD-I05** Intelligent Integrated  
Detector Base Sounder, Detector  
White with Isolation

**BSS-DR-N05** Intelligent  
Integrated Detector Base Sounder  
Strobe -Detector White

**BSS-DR-I05** Intelligent Integrated  
Detector Base Sounder Strobe,  
Detector White with Isolation

# FAAST – Fire Alarm Aspiration Sensing Technology

FAAST series features, with advanced high and ultra-high sensitivity smoke detection and nuisance rejection technology that make it the best choice for Early Warning and Very Early Warning fire detection in the industry



## XS 7100X

- Conventional FAAST Single Inlet with Modbus/TCP protocol with a coverage area up to 5,000 sq. ft. (464 sq. m.).
- Intuitive user interface with alarm level, airflow readout, general fault indication, and LCD for detailed information.



## XM 8100

- 8100 Conventional FAAST Single Inlet with Modbus/TCP protocol with a coverage area up to 8,000 sq. ft. (743 sq. m.)
- With its 5 configurable sensitivity levels and the Acclimate™ mode, programmable delays, FAAST XM can be tailored to the most demanding fire-risk management scenarios.



## XM 9400X

- Conventional FAAST XT 4-Pipe Inlet with Modbus/TCP protocol with a coverage area up to 28,800 sq. ft. (2,676 sq. m.)
- The device is fully configurable, with 5 programmable sensitivity levels, 3 selectable fan speeds, and offers an LCD and USB for ease of programming and device interaction.

# Fire-Lite Fire Alarm Panel

## MS-9050UDE

- Single SLC loop supports up to 50 addressable points of any type.
- Integrated DACT for off-premises
- NACs: Two Class A/B with built in synchronization.
- ANN-BUS supports ANN-80 LCD Annunciator, ANN-S/PG Serial/Parallel Printer Interface and ANN-LED.
- Autoprogramming feature for quickly configuring detectors, modules and annunciators.



## MS-9600LSE

- Up to 636 addressable points with optional second SLC loop (318 devices per loop).
- FAST LiteSpeed SLC communications protocol polls 10 devices at a time and operates on standard unshielded wire.
- Autoprogrammable
- 7 amp switching power supply
- Programmable via on-board keypad, PC keyboard, or local laptop.



# System Sensor Conventional Modules & Devices



AV



BEAM



CO



HVAC



SPOT



SPRINKLER



MODULES



RELAYS



**Audible/Visible  
Notification**



**Beam Smoke  
Detection**



**Linear Heat  
Detector**



**Smoke  
Detection**



**Fire Sprinkler  
Systems Monitoring**



**HVAC Duct  
Smoke Detection  
and Monitoring**





# Why Choose NOTIFIER?

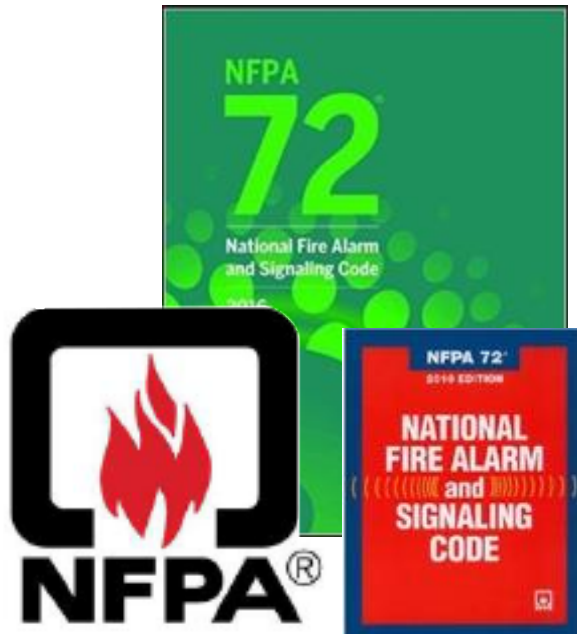

All aspect bundled with  
**Code Compliance**

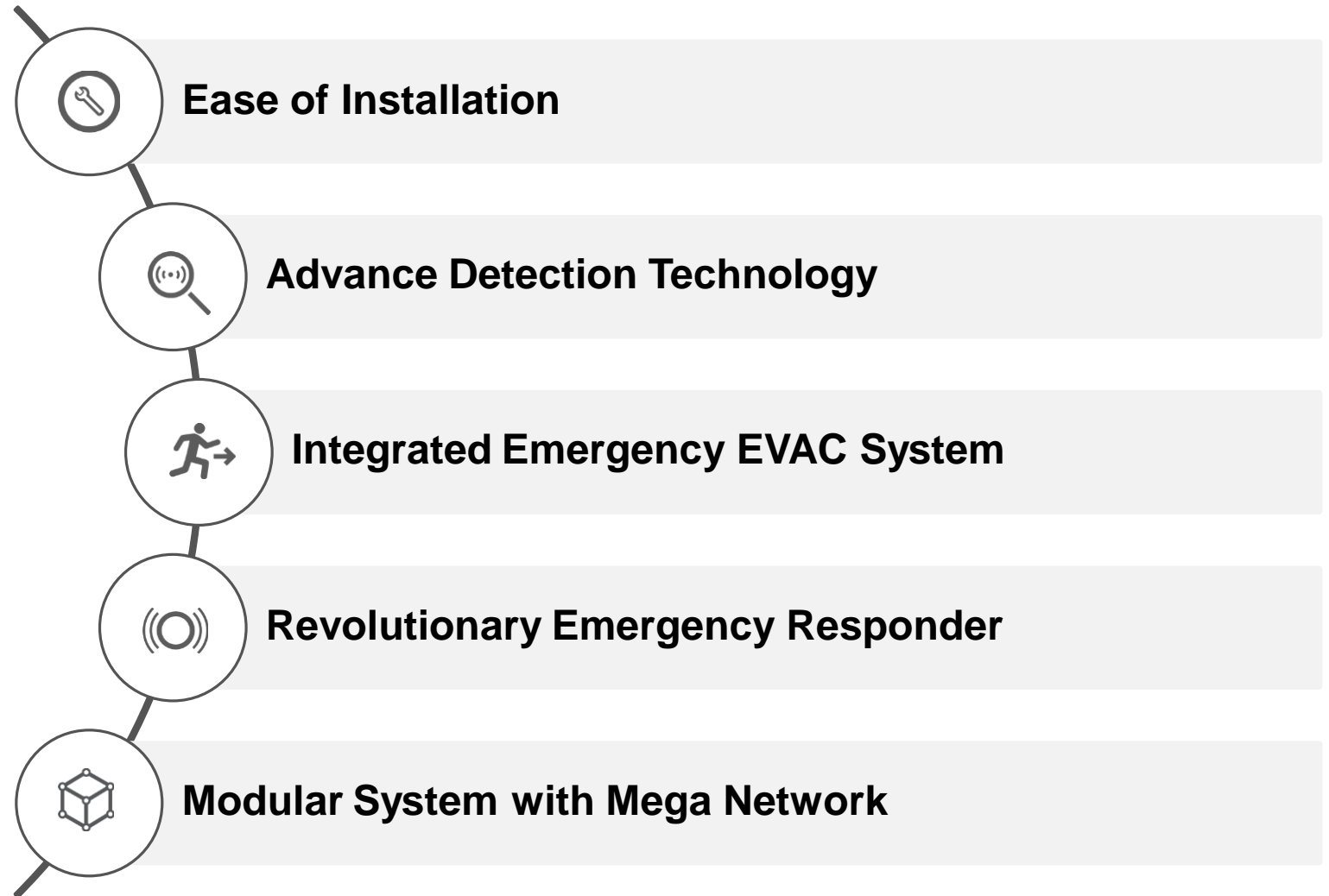

# Notifier: differentiator across verticals

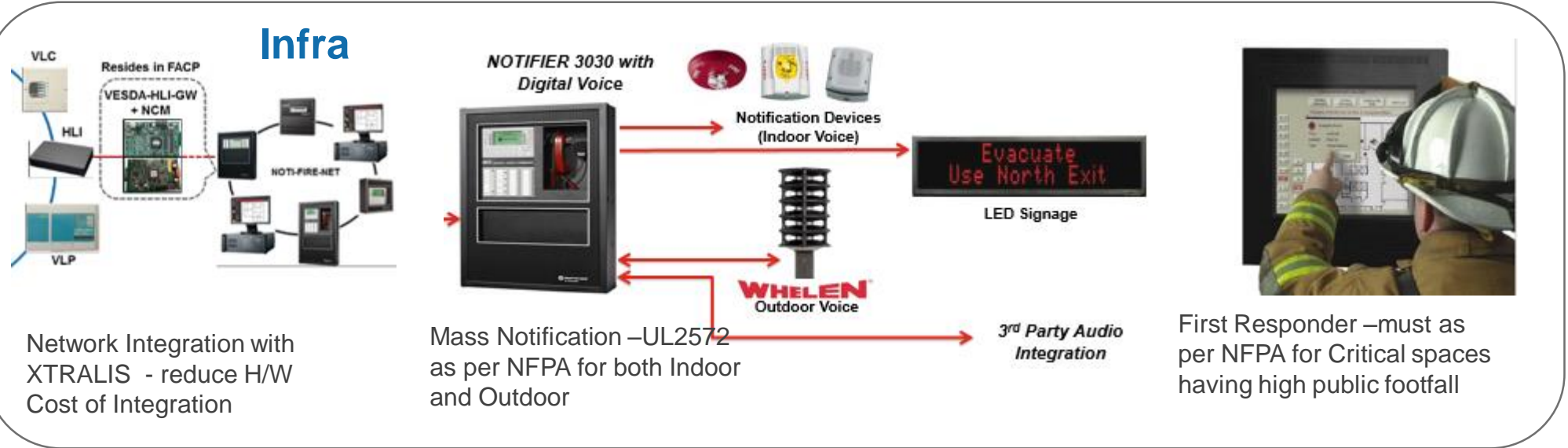

## Hotels



One device integrating Smoke + CO and Sounder – Large saving on Hardware and operation cost

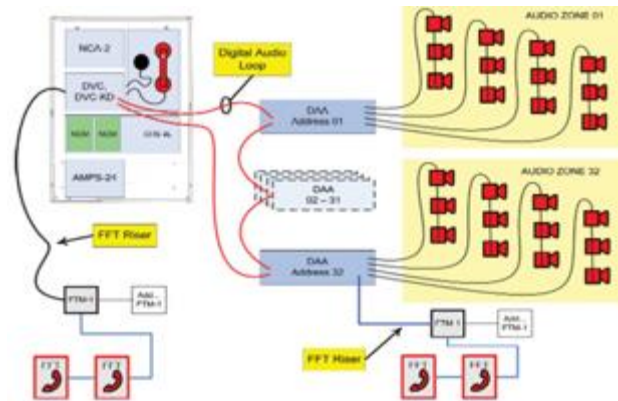

Built in VA an important aspect of NFPA and a critical requirement in HOTEL as per UL norms → reduced cabling



# Notifier: differentiator across verticals



Large Network on High Speed for 200 Panels + Voice over IP → ideal for Township Application

## Township

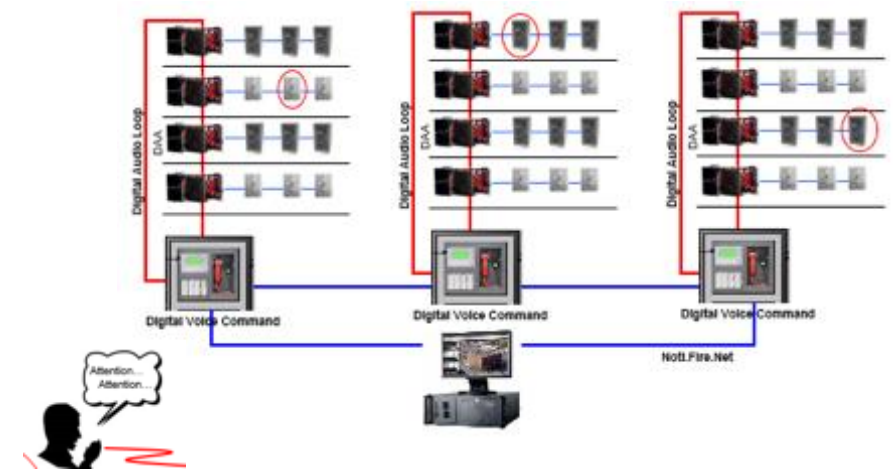

## High rise Residences

- Maximum Device Capacity on single Loop reduces Home Run
- Unshielded cabling makes Notifier more attractive in the overall cost of Bidding



- QWERTY Keypad and Large display enable easy viewing & programming of the system on site
- Hard Addressing Offers easy installation of the complete system w/o any dependency on software or Laptop



# Public Address Voice Alarm

Looking for a highly flexible, enjoyable and creditable integrated public address and voice alarm solution for your building? Honeywell has a comprehensive range that integrates with other systems to provide the best protection for your property, assets and human lives in all situations

# What is Public Address + Voice Alarm?

- **Public Address system (PA system)** is a system of microphones, amplifiers and loudspeakers used to amplify speech or background music (BGM) in a larger building or at an outdoor gathering. PA systems are used in any public venue that requires that an announcer, performer, etc. be sufficiently audible at a distance or over a large area.
- **Voice Alarm system (VA system)** (sometimes referred to as a voice evacuation system) is installed with the safety of staff and general public in mind. It is a system that assists in the effective evacuation of an area or building during a fire, bomb alert or other emergency situations.



# X618 Product Range



## X-DCS2000/EN

Digital Integrated System Manager, 8 Zones, Multi-Functional Integration, without PTT microphone

## X-DCS3000

Digital Integrated System Manager, 8 Zones, Multi-Functional Integration



**HN-PTT** Optional Push-to-talk Microphone

**X-NPMI** Configurable Network Paging Console, 4.3" Color Touch Screen, Suitable for Desktop Flush Mount



**X-NPMS** Advanced 7" TFT Touch screen Paging Station with Programmable Hard button keys



**X-DA2250EN** High Efficiency Class D Power Amplifier, 2x250W, 100V/70 Output, with 100 - 240 VAC input and 24 VDC backup power Supply

**X-DA1500EN** High Efficiency Class D Power Amplifier, 1x500W, 100V/70 Output, with 100 - 240 VAC input and 24 VDC backup power Supply

**X-DA4125EN** High Efficiency Class D Power Amplifier, 4x125W, 100V/70 Output, with 100 - 240 VAC input and 24 VDC backup power Supply

**X-DA2250** High Efficiency Class D Power Amplifier, 2x250W, 100V/70 Output, with 220 VAC UPS input

**X-DA1500** High Efficiency Class D Power Amplifier, 1x500W, 100V/70 Output, with 220 VAC UPS input

**X-DA4125** High Efficiency Class D Power Amplifier, 4x125W, 100V/70 Output, with 220 VAC UPS input

**X-DA4060** High Efficiency Class D Power Amplifier, 4x60W, 100V/70 Output, with 220 VAC UPS input



**X-MAP04** All-in-1 Audio Source Unit (Include pre-amplifier), CD/MP3/FM/DAB, with RS485 Protocol Interface



**X-NRI/EN** Network Resource Interface, 4 channels network audio source, 32 dry contacts in and 8 try contacts out



**X-SPT900** X-SMART Med to Small Project System Management Software Package (Include 1 server and 1 client interface)  
**X-SP2000** X-SMART System Resource Platform (Server)  
**X-ST2000** X-SMART Client Interface



**HN-D32N** Noise detector, Transmission Distance up to 200 Meters



**HN-VC06** 6W Volume controller, 3/4 wire, ABS Material, with 24V Override Function

**HN-VC30** 30W Volume controller, 3/4 wire, ABS Material, with 24V Override Function

**HN-VC60** 60W Volume controller, 3/4 wire, ABS Material, with 24V Override Function

**HN-VC120** 120W Volume controller, 3/4 wire, ABS Material, with 24V Override Function



**HN-RTR** IP/Analog Interface Converter

# Variodyn D1 Product Range



## Digital Output Module DOM4-8 Digital Output Module DOM4-24

DOM is a central control element of Variodyn D1. It has interfaces to all input/output assemblies, administers and monitors of loudspeaker circuit. DOM4-8 has 4 independent channels for operate 8 loudspeaker circuits. DOM4-24 has 4 independent channels for operate 24 loudspeaker circuits. 16 audio slots total 1 hour memory. All functions alarm and evacuation system. Networkable into large system via Ethernet connection.



## Universal Interface Module UIM

UIM serve as the interface module for connecting two analog audio inputs/outputs, as well as 48 control contacts freely programmable as inputs and outputs. Digital Audio Link(DAL) to DOM.



## Compro 4-8 (Stand alone without Ethernet) Compro 4-24 (Stand alone without Ethernet)

The central control panel of a Variodyn D1 system for small and medium sized projects. 4 channel parametric equalizer, compressor/limiter and delay. All functions alarm and evacuation system. Automatic and dynamic switching of backup amplifier. Automatic volume control (AVC) even during announcements.

## Compro 4-8 net (with Ethernet) Compro 4-24 net (with Ethernet)

The central control panel of a Variodyn D1 system for small and medium sized projects. 4 channel parametric equalizer, compressor/limiter and delay. All functions alarm and evacuation system. Automatic and dynamic switching of backup amplifier. Automatic volume control (AVC) even during announcements.



## System Communication Unit SCU

The SCU serves as a digital audio memory for the Variodyn D1 system. It is possible to record and playback multiple audio data streams simultaneously and networkable via Ethernet.

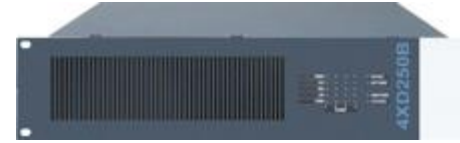

**2XD250** High efficiency Class D power amplifier, 2 channels x125W, 100V/70V output, with 100-240 VAC input and 24 VDC for backup mains power.

**2XD400** High efficiency Class D power amplifier, 2 channels x400W, 100V/70V output, with 100-240 VAC input and 24 VDC for backup mains power.

**4XD125B** High efficiency Class D power amplifier, 4 channels x125W, 100V/70V output, with 100-240 VAC input and 24 VDC for backup mains power.

**4XD250B** High efficiency Class D power amplifier, 4 channels x250W, 100V/70V output, with 100-240 VAC input and 24 VDC for backup mains power.

**4XD300** High efficiency Class D power amplifier, 4 channels x300W, 100V/70V output, with 100-240 VAC input and 24 VDC for backup mains power.

**4XD500** High efficiency Class D power amplifier, 4 channels x500W, 100V/70V output, with 100-240 VAC input and 24 VDC for backup mains power.



## Fiber Optic Converter

Multimode fiber and single mode module. Ring structure with rebuilding feature.



## Loop Isolator Module LIM

Higher security A/B cabling and no speaker loss in case of cable break.



## Digital Call Station DCS

1 and 12 buttons with one audio in-/output.  
**DKM18** with 18 buttons.  
**DIGIM1 and DIGIM4** simple call station.

# Public Address Series Speaker

## Ceiling Loudspeaker



**L-PCM06E** 6.5" ceiling loudspeaker, 6/3/1.5W, white, Metal  
**LM2-MMB** Metal dome for L-PCM06E  
**L-PCM06A** 5" ceiling loudspeaker, 6/3/1.5W, white, metal  
**L-PCM06B** 6.5" Ceiling loudspeaker, 6/3W, white, Metal, Metal dome  
**L-PCP06A** 3" ceiling loudspeaker, 6/3W, white, ABS  
**LM2-PCP06A** 5" ceiling loudspeaker 6/3/1.5W, white, ABS  
**LM2-PCP06B** 5" ceiling loudspeaker, 6/3/1.5W, white, ABS, ABS dome  
**LM2-PCP06C** 5" ceiling loudspeaker, 6/3/1.5W, white, ABS, moisture-proof IP54  
**LM2-PM** lame-proof ABS back dome, work with LM2-PCP06A/LM2-PCP06C  
**LM2-MHA** Bracket, work with LM2-PCP06x series, metal, white, for suspended installation  
**L-PCP06B** 6.5" ceiling loudspeaker, 6/3W, white, ABS  
**L-PCP06C** 6.5" ceiling loudspeaker, 6/3W, white, ABS, moisture proof IP54  
**L-PCP20A** 6" ceiling loudspeaker, 20W, white, ABS

## Wall-mount Loudspeaker



**L-PWP03A** Wall mount loudspeaker, 3/1.5W, white, ABS  
**L-PWP06A** Wall mount loudspeaker, 6/3W, white, ABS  
**L-PWP06B** Wall mount loudspeaker, 6/3W, white, ABS  
**L-PWP10A** Wall mount loudspeaker, 10/5W, white, ABS

## Cabinet Loudspeaker



**L-PWP40A** Wall mount cabinet loudspeaker, 40/20/10W, white, ABS  
**L-PWP40B** Wall mount cabinet loudspeaker, 40/20/10W, black, ABS  
**L-PWP60A** Wall mount cabinet loudspeaker, 60/30/15W, white, ABS  
**L-PWP60B** Wall mount cabinet loudspeaker, 60/30/15W, black, ABS  
**L-PWP80A** Wall mount cabinet loudspeaker, 80/40/20W, white, ABS  
**L-PWP80B** Wall mount cabinet loudspeaker, 80/40/20W, black, ABS

## Horn Loudspeaker



**L-PHP15A** Horn loudspeaker, 15/7.5W, white, ABS  
**L-PHP30A** Horn loudspeaker, 30/15W, white, ABS  
**L-PHP50A** Horn loudspeaker, 50W, French grey, ABS

## Projection Loudspeaker



**L-PJP20A** Projection loudspeaker, 20/10W, white, ABS  
**L-PBM20A** Bidirectional projection loudspeaker, 20/10/5/2.5W, White, Aluminum  
**L-PJM10A** Unidirectional projection loudspeaker, 10/5/2.5/1.25W, White, Aluminum  
**L-PJM20A** Unidirectional projection loudspeaker, 20/10/5/2.5W, White, Aluminum

## Pendant Loudspeaker



**L-PPP20A** 8" Pendant speakers, 20/10/5W, white, ABS

## Column Loudspeaker



**L-POM20A** Outdoor Column loudspeaker, 20/10/5/2.5W, White, Aluminum  
**L-POM40A** Outdoor Column loudspeaker, 40/20/10/5W, White, Aluminum  
**L-POM80A** Outdoor Column loudspeaker, 80/40/20/10W, White, Aluminum



# Voice Alarm Series Speaker

## Ceiling Loudspeaker



**L-VCM6A/EN** 6.5" Fire proof metal ceiling loudspeaker, 6/3/1.5/0.75W, red fire dome, EN54-24

**L-VCM6B/EN** 5" Fire proof metal ceiling loudspeaker, 6/3/1.5/0.75W, red fire dome, EN54-24

**L-VCM24A/EN** 6.5" Fire proof metal coaxial ceiling loudspeaker, 24/12/6/3W, 4ohm, red fire dome, EN54-24

## Cabinet Loudspeaker



**L-VWM06A/EN** 4" Fire proof metal wall mount loudspeaker, 6/3/1.5/0.75W, white metal enclosure, EN54-24

## Horn Loudspeaker



**L-VHP15A/EN** Fire proof outdoor horn, 15/10/5W, 8ohm, Grey, ABS, EN54-24, with capacitor

## Projection Loudspeaker



**L-VJM10A/EN** Fire proof unidirectional loudspeaker, 10/5/2.5/1.25W, White, Aluminum, EN54-24

**L-VJM20A/EN** Fire proof unidirectional projection loudspeaker, 20/10/5/2.5W, White, Aluminum, EN54-24

**L-VBM20A/EN** Fire proof bidirectional speaker, 20/10/5/2.5W, White, Aluminum, EN54-24

## Column Loudspeaker



**L-VOM20A/EN** Fire proof outdoor column speaker, 20/10/5/2.5W, White, Aluminum, EN54-24

**L-VOM40A/EN** Fire proof outdoor column speaker, 40/20/10/5W, White, Aluminum, EN54-24

# INTEVIO Public Address & Voice Alarm System

- Expandable up to 128 zones
- Built-in scheduler and timer for automating tasks
- USB Port for streaming audio files
- Record and playback function
- Pre-configured default setting



- Dynamic Amplifier backup : One stand by amplifier can be used for the entire system.
- Power Save Mode : When amplifier is idle, it will enter the power save mode.
- Controller with built in 500W amplifier can work as a stand alone 8 zone PA system.
- Step-by-step guide on the LCD screen for better operation efficiency.
- Direct paging : User can make an all call even if the CPU is dead.
- Application : Office building, hotel, school, house of worship, retail shops.

# Compact PA Product Range



- 5 zone compact mixer and paging system with integrated CD/MP3/WMA audio player, FM/MW(AM) tuner as optional.
- Class-D amplifier with 3 models HN-5120R(120W), HN-5240R(240W) & HN-5300R(300W).
- 3-level priority with mute function and 7-band graphic equalizer.
- Application : Small office, restaurant, budget hotel, retail shops.



# Compact PA Product Range

**EVAC**  
LITE Sound of Safety



**EVACLITE : 8 Zone Voice Alarm controller with built-in USB, MP3, AM/FM player and 8 zone paging station**

- 8 zone paging system with voice alarm controller for voice evacuation (pre-recorded messages).
- Simple integration with fire alarm panels to activate EVAC/Alert pre-recorded messages.
- Built-in MP3 (USB) and AM/FM tuner functions.
- 8 broadcast zone output function, the peak of each zone is 400W and total power for all 8 zone is 1000W
- Application : Small office, restaurant, budget hotel, workshop, retail shops.



Column Loudspeaker



Pendant Loudspeaker



Horn Loudspeaker



Ceiling Loudspeaker



Projection Loudspeaker



Cabinet Loudspeaker

# Honeywell Integrated Security Fire Scenario Example

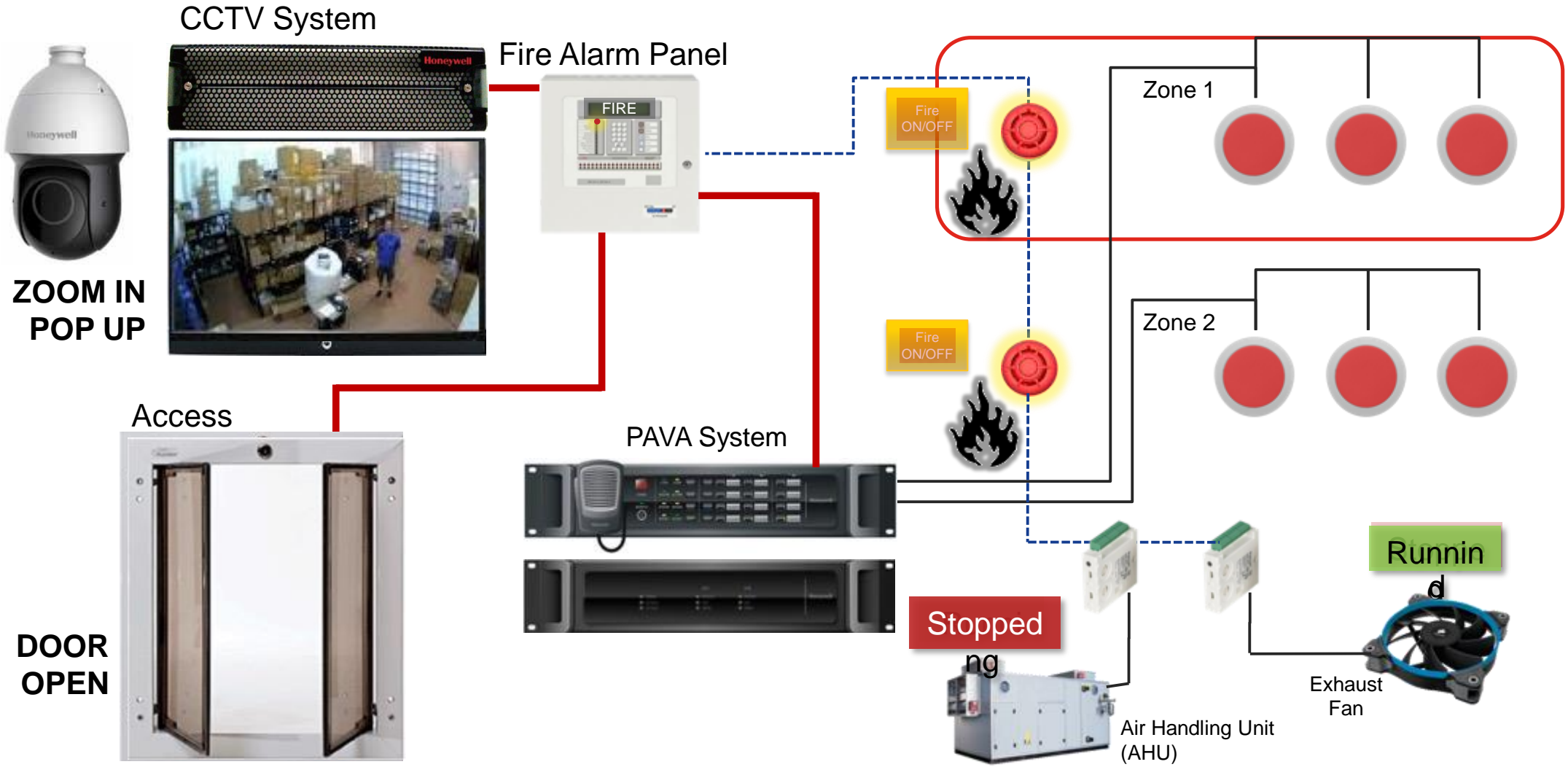

# Global Field Devices

A comprehensive range of Honeywell branded, compatible and quality guaranteed HVAC field devices, suitable for all control brands

# Typical HVAC system in a building

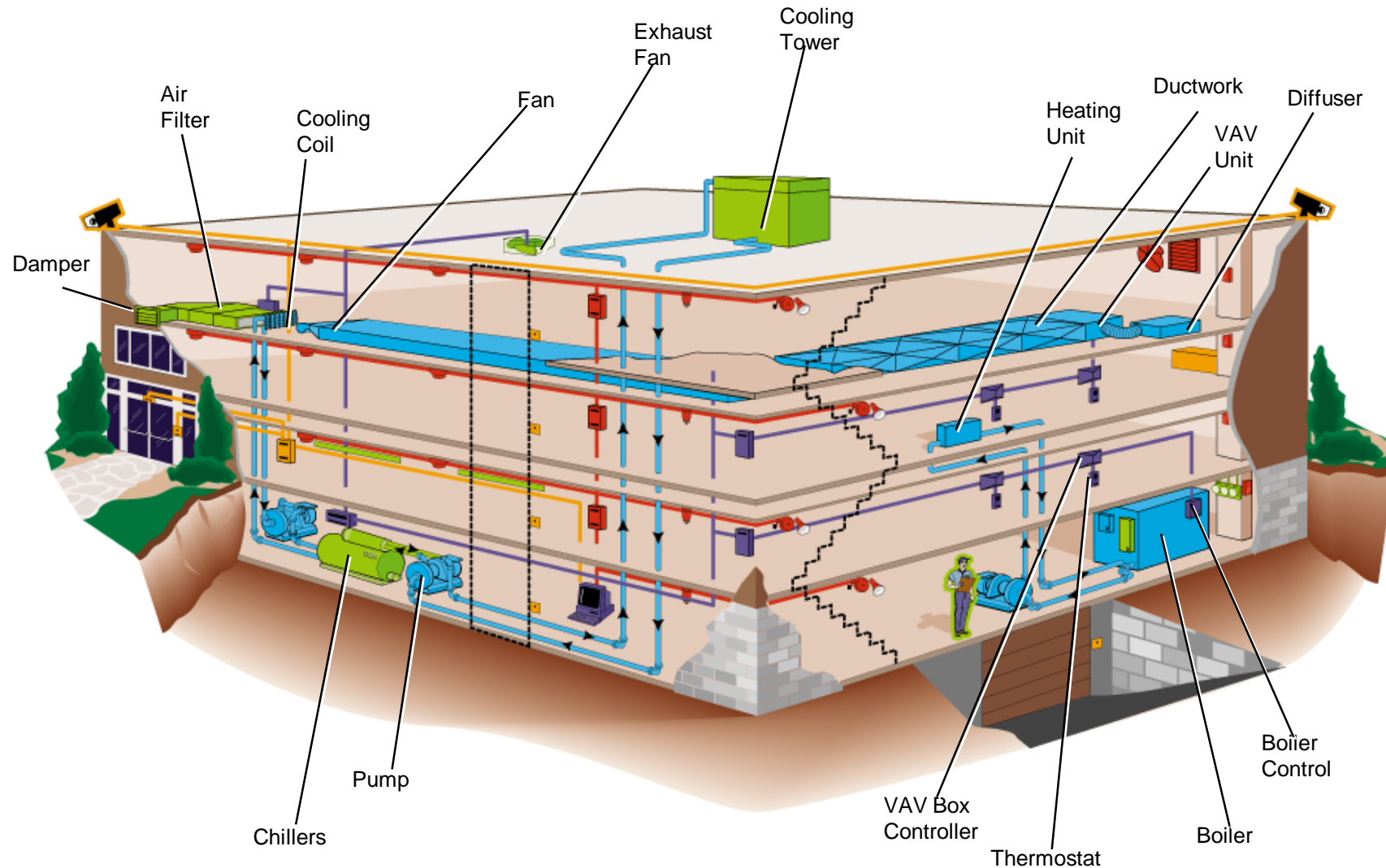

# Field device offerings in a building

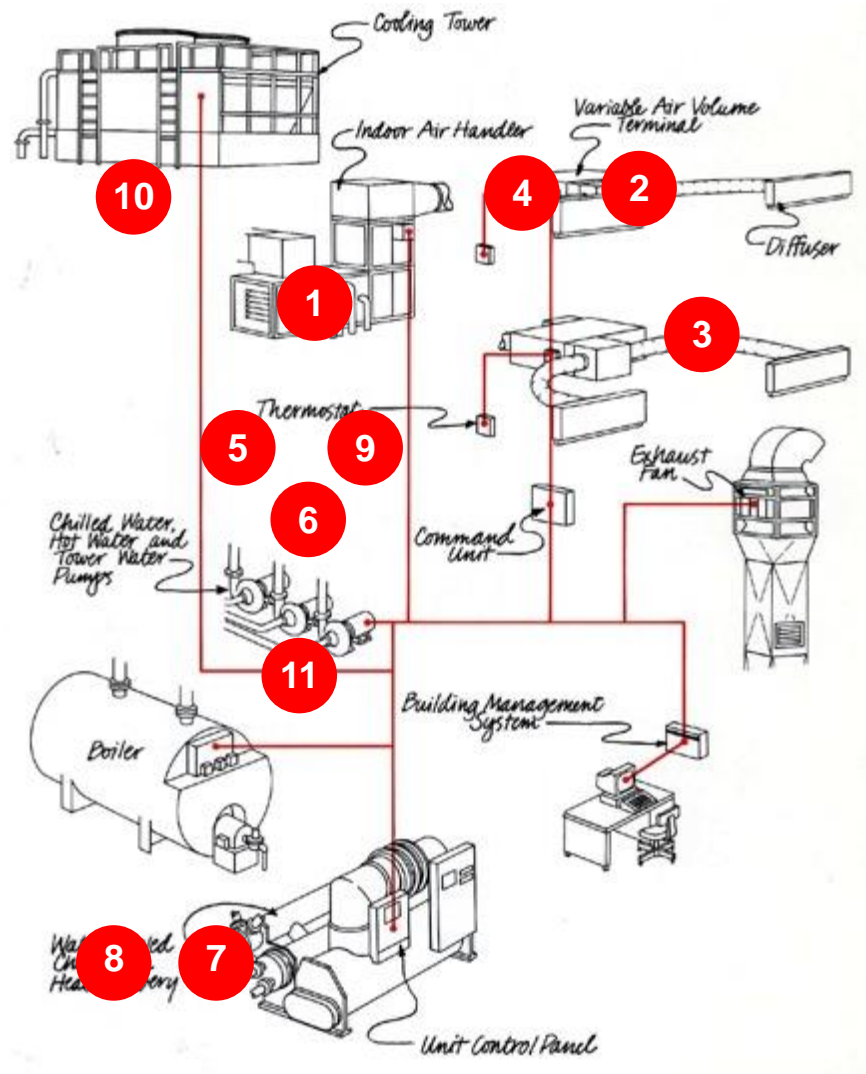

## Field Device Applications\*

- AHU Unitary Controller
- DCA
- Temperature/Humidity Duct Sensor
- Different Pressure Sensor
- HVAC Linear Actuator
- Globe Valve
- Balancing Valve
- Motorized Butterfly Valve
- Motorized Ball Valve
- Manual Valve
- VFD

\*The label shows on graphic is just for example



# Field Devices

## Damper Solutions



## Hydronic Balancing

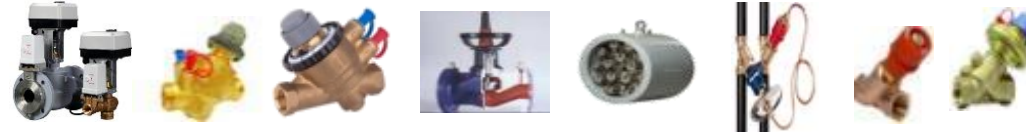

## HVAC Controls



## Plumbing



## Sensors



## BTU



## Field Devices



### OFFERING DESCRIPTION:

A comprehensive range of Honeywell branded, compatible and guaranteed HVAC field devices, suitable for all control brands.

### KEY FEATURES:

One stop shop for all HVAC control requirements.

## INSTALLER / CHANNEL SEGMENTS

### RELEVANT SEGMENTS:

- Partner Channels
- OEM
- Direct - HBS

### SEGMENT'S MOST DIFFERENTIATING NEED:

- "One Stop Shop"
- Single source of supply
- Honeywell brand

### TYPICAL OFFERINGS USED BY SEGMENT:

- Multiple manufacturing suppliers
- Multiple sources of supply (distribution / trade / wholesale)

### HONEYWELL Vs NBA:

- Honeywell Economic Advantage over individual manufacturers
- Feature – "One stop shop" catalogue of guaranteed compatible devices from single manufacturer
- Benefit – Quick easy product identification from a single supplier
- Economic value – Single account to negotiate and manage

### COMMON PITFALLS TO AVOID

- Range limited breadth/depth – core items per range only
- Known BTS – guarantee from Honeywell, fully compatible
- Delivery discussions – consolidation reduces shipments and administration

### OTHER HON PRODUCTS THEY MAY NEED / DESIRE

- Honeywell control brands
- Honeywell Life safety product ranges
- Honeywell Security product ranges
- Honeywell Hospitality offerings



## END USER SEGMENTS

### RELEVANT SEGMENTS:

- Specifiers
- Main Contractors
- M&E Contractors

### SEGMENT'S MOST DIFFERENTIATING NEED :

- Reduced number of suppliers
- Single point of contact
- Recognised single manufacturer

### TYPICAL OFFERINGS USED BY SEGMENT :

- Multiple manufacturing suppliers
- Multiple sources of supply (distribution / trade / wholesale)

### HONEYWELL Vs NBA:

- Honeywell Economic Advantage over multiple suppliers
- Feature – Single large recognised supplier
- Benefit – reduced risk
- Economic value – increased bargaining power

### COMMON PITFALLS TO AVOID

- Range breadth/depth – core items per range only
- Known BTS – guarantee from Honeywell, fully compatible
- Delivery discussions – consolidation reduces shipments and administration

### OTHER HON PRODUCTS THEY MAY NEED / DESIRE

- Honeywell Life safety product ranges
- Honeywell Security product ranges
- Honeywell Hospitality offerings
- Honey direct (HBS)



# Building Management Systems

For all your needs of Control solutions, across verticals, there is a precise brand, that you can customize

# Building Management Systems

- Proven track record, across geographies
- “Just in time” efficient manufacturing
- Experienced System Integrator network, very close to customers
- Honeywell support across lifecycle
- Customization & Integration support for Green Buildings, complex projects



Trend BMS



WEBS-N4 BMS



Alerton BMS



Inncom GRMS



Saia Burgess



Phoenix Controls



Ex-or

# Trend BMS for Commercial Office Spaces & Hotels

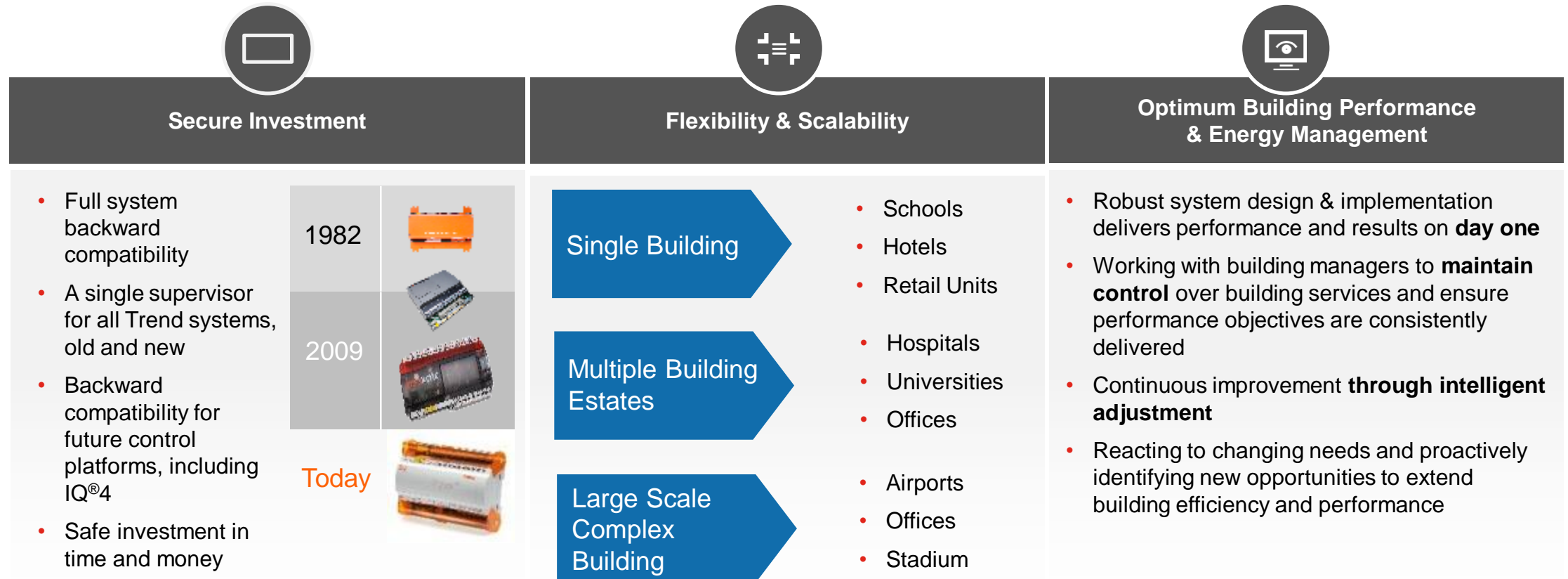

# Trend IQVision, IQ4 System System Features





Forward & Backward Compatibility	Integration	Stable & Reliable System	Flexible I/O Configuration	Easy Engineering	Longer Bus & Distributed I/O	Reduced Panel Size
<ul style="list-style-type: none"> <li>• Protects value of investment</li> <li>• Hassle free project expansion</li> <li>• Assured warranty support</li> </ul>	<ul style="list-style-type: none"> <li>• Ease of Integration with diverse MEP systems</li> <li>• Customized Dashboards &amp; Reports</li> <li>• Leverages the powerful Niagara Platform</li> </ul>	<ul style="list-style-type: none"> <li>• Rugged Industrial Processor, with RTC, True Peer to Peer communication</li> <li>• BACNet over IP</li> <li>• BTL &amp; UL Listed</li> </ul>	<ul style="list-style-type: none"> <li>• With the ability to upgrade between its available 16, 32, 64, 96, 128, 160 and 192-point variants, applications of all sizes can have a better matched control solution, thus reducing unused I/O and creating significant cost savings</li> </ul>	<ul style="list-style-type: none"> <li>• With new strategy modules and soft addressing, IQ@4E reduces the amount of time spent on each project. Not only does this reduce cost, it makes better use of a valuable time and engineering resource, particularly when combined with SET 7.0 Voice Commissioning.</li> </ul>	<ul style="list-style-type: none"> <li>• The IQ@4E has improved I/O bus capabilities, with an available length of up to 300m and the potential for 30 I/O modules to be configured. Perfect for when I/O is required in other areas of the plant room.</li> </ul>	<ul style="list-style-type: none"> <li>• With its small footprint IQ@4E can be placed in smaller control panels, lending itself to confined space applications</li> </ul>

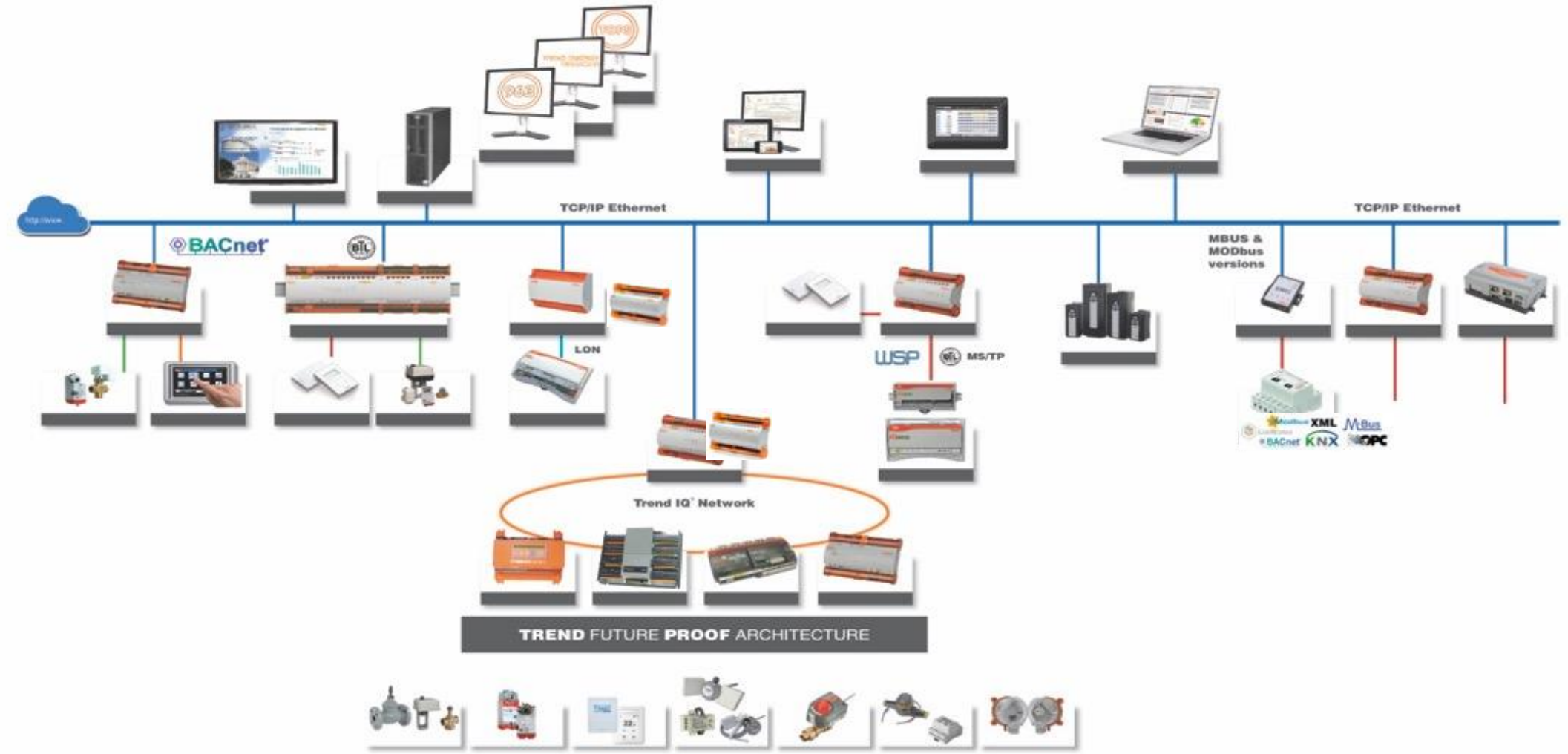

# Trend System Architecture



# Trend System Components

IQ4 Controller	IQ4NC Node Controller	Supervisor Protocol	TONN	IQ4XNC Controller
			 <p>MBUS MODbus KNX</p>	
<ul style="list-style-type: none"> <li>• Protocol options</li> <li>• BACnet, XML, MODBus, Mbus</li> </ul>	<ul style="list-style-type: none"> <li>• MSTP/Ethernet</li> <li>• BACnet devices</li> <li>• Trend Native BACnet IQ@eco or 3rd party devices</li> </ul>	<ul style="list-style-type: none"> <li>• Trend BACnet via TONN:</li> <li>• BACnet, KNX, LON,</li> <li>• MODBus, MBus,</li> <li>• oBIX, SNMP</li> <li>• SQL Database</li> <li>• CSV files</li> </ul>	<ul style="list-style-type: none"> <li>• Open Protocols</li> <li>• Trend, BACnet, KNX, LON, MODBus, MBus, oBIX, SNMP</li> </ul>	<ul style="list-style-type: none"> <li>• Interfacing Flexible interfacing with 3rd party systems</li> <li>• Enhanced Custom Language (TCL)</li> <li>• Standard IQ configuration modules</li> </ul>



# Trend IQVision



# Electrical Products

Complete range of wiring devices to meet the requirements of buildings for different applications

# Electric Product Wiring Devices

- Wide global and regional WD ranges
- E2R & local manufacturing footprints
- Strong brand with market presence
- Multi-channel strategy within country
- Focus on residential and commercial segments
- Align to end segments growth drivers and verticals



Elements  
WD



PRANA  
WD



R series  
WD



Slimline Plus  
WD



ECORE SR  
WD



Plug top  
Accessories



Metalclad Plus  
WD



Isolator



Masterseal









Weathershield



C2 series  
WD

# Electrical Product Wiring Devices Range

 Elements	 PRANA	 R-series	 Slimline Plus	 ECORE SR	 Metalclad Plus	 Masterseal Compact
<ul style="list-style-type: none"> <li>• 16 beautiful colors, materials, finishes in the premium range</li> <li>• Electronic touch high tech feel E-dimmers &amp; switches</li> <li>• Extensive range for high-end hospitality, residential or commercial requirements</li> <li>• Design customization available</li> </ul>	<ul style="list-style-type: none"> <li>• Unique big switch with 3-dots LED indicators and European style symmetric profile</li> <li>• Easy side-by-side and 5 unit-panel multi-gang installation</li> <li>• Comprehensive range for diverse requirements</li> <li>• 3 contemporary colors: White, Golden Amber, Silver Titanium</li> </ul>	<ul style="list-style-type: none"> <li>• Curved profiles with soft modern look and 7mm thickness</li> <li>• Easy side-by-side installation allows for clean aesthetics</li> <li>• Rotatable orientation for all switches</li> <li>• Comprehensive range for residential, hospitality or commercial</li> <li>• Choice of White or 3 modern attractive colors</li> <li>• Availability up to 4 unit-panel gang</li> </ul>	<ul style="list-style-type: none"> <li>• Stylish profile with surround clip on</li> <li>• Complete range to fulfil residential or hospitality specifications</li> <li>• Choice of white plastic and color options</li> <li>• Availability of multi-panel gang surrounds</li> </ul>	<ul style="list-style-type: none"> <li>• Simple surround clip on aesthetic design</li> <li>• Manufactured from quality PC materials</li> <li>• Fully compliant with MS/ BS/ IEC standards as a basic choice for residential and replacement</li> </ul>	<ul style="list-style-type: none"> <li>• Made from heavy gauge steel, tough and impact resistant.</li> <li>• Complete range where heavy wear performance is needed</li> <li>• Front plates with smoothly chamfered edges providing a neat finish when fitted with the backbox</li> </ul>	<ul style="list-style-type: none"> <li>• IP66 waterproof and dustproof</li> <li>• Durable material and robust construction</li> <li>• Made of high quality PC which prevents discoloration, cracking or fading in UV light</li> <li>• Temperature tolerant, reliable in operation under outdoor installations</li> </ul>

# Electrical Product Wiring Devices: Benefits



## Superior aesthetics: design, colors, materials and finishes

- Elements Premium design with 16 CMF
- PRANA European design with LEDs
- R series curved design with 3 colors
- SL+ chamfer design with colors options
- ECORE SR simple design with WHITE plastic



## Ease of installation and range of applications

- 16AX for more light spots
- Comprehensive and breath of SKU availability: Switches, Sockets, Data, TV, etc...
- Easy side by side installation
- Rotatable switches
- Multi-panel ganging plate



## High Quality Product

- Test and compliance to MS/SS/IEC standards
- Obtain certification of local authority
- Made from high quality PC material
- High quality assurance in manufacturing process

# Air & Water

Comprehensive range of solutions for better quality of air, water, security for businesses and families

# Residential Building: Quality Lifestyle Concept



Purifying air pollutants such as PM<sub>10</sub>, PM<sub>2.5</sub>, formaldehyde and TVOC that build up from daily activities or chemical gases emitted from products used indoors

- Honeywell Air Touch range Air Purifiers are completely 'Ozone Free', does not emit any harmful gases as a byproduct of the filtration technology
- The filtration system is made with a U.S. patented formula, HiSiv™ filter that removes >99% formaldehyde, toxic gases, odours & TVOC; while HEPA filter delivers >99.9% PM2.5 removal efficiency.
- Easy to use, easy to install, and easy to maintain

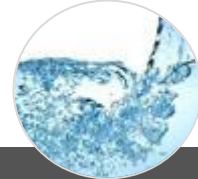

Safe drinking water especially for individuals with sensitive stomach/ gastroenteritis. Clean water that has undergone proper filtration for health and longevity

- Honeywell RO Filtration system removes heavy metals and bacteria in the water and filters down to 0.0001 micron contaminants to ensure pure and safe drinking water for daily consumption
- A simple and elegant design for easy cartridge replacement, no need for professional service visits.



For home/ building owners that need to interact with the guard house for visitor management, intercom neighborhood community, for enhanced security and protection

- Intelligent LCD screen with fingerprint/ password/ mechanical key unlocking modes for simple and easy operation.
- A digital intercom system equipped with multiple functions including visitor management, protection of property, communication, information announcement and elevator control

# Connected Living Solution

## Supported Features

PM2.5 Digital Display	Tool-free DIY Filter replacement	Smooth Touch Control Panel	Filter Replacement Indicator	Award winning design	Temperature control	FAR $\leq 0.001\%$
Monitor pollution in your home, that is invisible to the naked eye	Clean and easy filter replacement, no need for professional service visits	Intuitive touch control for easy operation	Accurately notifies which filter needs to be changed by the number that lights on	The sleek design enhances your décor while ensuring product quality for better health and safety	Plug & play with 3-stage RO filtration system available at 4 instant water temperatures for multiple users	Low false acceptance rate for 3x enhanced safety
						



# Connected Living Portfolio

## Air

### Consumer

#### In-car



Move Pure

#### Low-Mid



A5 (250CADR)



i8 (300CADR)

#### Mid-High



AT (300CADR)



AT (300CADR)

#### Premium (Add-on)



X (700CADR)



X3 (600CADR)

### Commercial

#### EAC



F52 Mounted



F58 Inside Duck/ AHU



F57A Mounted



F90A Mounted/

## Water

### Point-of-use

#### RO (0.0001micron)



AT-RO-75 Under-sink



HRO-400 Under-sink



HRO-50 Under-sink

New



Water Station Table Top Instant Heating

#### UF (~0.04micron)



HU-20 Under-sink



HU-30 Table Top



Pitcher Portable

## Connected Living

### Smart Lock

New



DDL-1000 (finger print, password, key, card)

### Video Door Phone

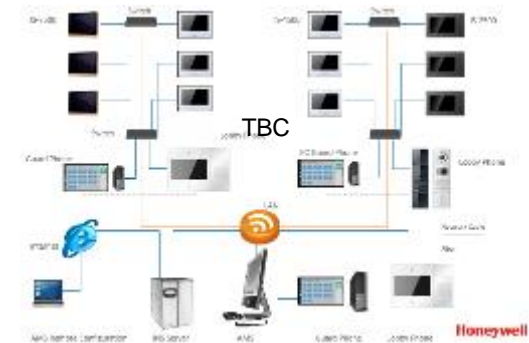

A low-angle, upward-looking shot of several modern skyscrapers with glass facades. The buildings are set against a clear, deep blue sky. The perspective creates a sense of height and scale, with the lines of the buildings converging towards the top of the frame. The lighting is bright, suggesting a clear day.

Honeywell is building a smarter, safer, and more sustainable world.

**That's the Power of Connected.  
That's the Power of Honeywell.**

**Honeywell**

THE POWER OF **CONNECTED**